

# Robotic Duct Sealing Enables Adequate Thermal Comfort, IAQ and Energy Efficiency

Bernt A. Askildsen, MSEE, MSTM  
PHD Candidate, Biomedical Engineering Department  
South Dakota School of Mines and Technology  
Rapid City, SD 57702  
[baskild@hotmail.com](mailto:baskild@hotmail.com)

Dr. Charles Tolle  
Electrical and Computer Engineering Department  
South Dakota School of Mines and Technology  
Rapid City, SD 57702  
[charles.tolle@sdsmt.edu](mailto:charles.tolle@sdsmt.edu)

## Abstract

Duct air leakage occurs in all Heating Ventilation and Air-Conditioning (HVAC) systems and affects the ability to provide adequate thermal comfort, indoor air quality and energy efficient operation. Due to the huge variety of HVAC configurations and environmental conditions this effort aims to address the core challenges and issues observed from a complete system perspective. In tandem, two new innovative methods are presented that properly quantify and then seal duct air leakage. Three actual duct sealing case studies then address some of the similarities and differences that exist. In a hospital operation room (OR) setting the observed problems were lack of thermal comfort for the surgeons, return fan noise pollution and limited cooling capacity for proper OR hygiene. Diagnosis documented substantial duct leakage in both return and supply air ductwork. At a separate location the bathroom exhaust did not properly ventilate odors and humidity from restrooms and toilets as there was a substantial discrepancy between exhausted and ventilated air. Robotic application of long-term reliable synthetic polymer sealants mitigated all reported issues and measurements quantified duct leakage reductions to 16%, 10% and 39% of overall airflows.

## 1 INTRODUCTION

The importance of energy efficiency in HVAC systems in health care, commercial and industrial buildings is continually increasing and the annual energy consumption for these in the United States alone exceed \$51 billion dollars [1-2]. Furthermore, the federal government owns or leases approximately 500,000 buildings that consume \$7 billion a year worth of energy. Other non-federal governments account for an additional \$11 billion annually in building-related energy bills [3]. HVAC systems running at limited energy efficiency typically also manifest themselves as buildings with poor indoor air quality (IAQ) and thermal comfort. For certain buildings these consequences are more economically devastating

than the actual waste of energy. Reduced worker productivity and comfort may be related to latent heat buildup, mold growth, odors, high CO<sub>2</sub> levels, air contamination, noise pollution etc [4-9].

Figure 1 illustrates a typical push-through HVAC system for warm climates where the fan pulls air from the building space as return air (R/A) and a portion becomes exhaust air (E/A) to meet ASHRAE 62.1-2007 [10] ventilation requirements. Fresh outside air (O/A) is pulled in to replace the E/A volume and will mix with the remaining R/A. The mixture of R/A and O/A have various air velocities and temperature profiles while being pulled through the filter bank by the fan. The fan then pushes the airflow to be heated or cooled (determined by the thermostat setting and/or ASHRAE 55-2004 [11]) before it propagates into the ductwork as supply air (S/A). The S/A flow is delivered to the various rooms by interconnected ductwork and associated diffusers. The filtered and conditioned flow provides humidity adjusted thermal comfort to support healthy and comfortable indoor environments for the building occupants [11-12].

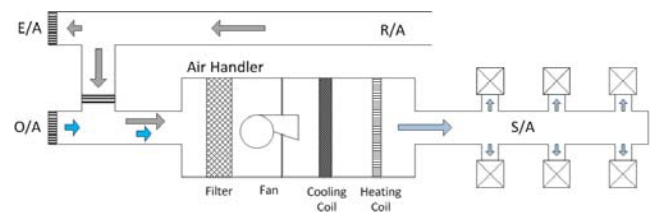

**Figure 1: A push-through HVAC system for warm climates (for cold climates coils switch positions).**

For HVAC systems air is directed through ducts or pipes. In general, commercial size ducts are made of sheet metal and used in low-pressure systems, while pipes are sturdier and used in higher-pressure ones. In most systems ducts are used on one or both sides of a fan and the ducts have a critical impact on fan performance. Friction between the airstream and the duct surface is usually a significant

portion of the overall fan load. Larger ducts create lower airflow resistance than smaller ducts but have higher initial costs in terms of material, space requirements and installation. However, the reduced cost of energy because of lower friction offsets some of these costs and should be included during the initial design process and during system remodeling/retrofit efforts. Other considerations with ducts are shape and leakage class. Round ducts have less surface area per unit cross section than rectangular ducts and, as a result, have less leakage. In hot or cool airstreams, this surface area also influences the amount of heat transferred to/from the surrounding environment.

Many factors cause duct leakage including duct profile, seams, joints, static pressure, openings, penetrations, sealants and workmanship. Another cause is service openings cut frequently by duct cleaners preferring contact vacuuming [13]. This cleaning procedure often results in altered ductwork integrity and can cause excessive duct leakage in tandem with elevated static pressures. Figure 2 is an example where a duct cleaning firm forgot to close an access point effectively eliminating ventilation and temperature control of six offices.



**Figure 2: An access point forgot by a duct cleaner allowing 2000 CFM S/A into non-conditioned space.**

Duct leakage is a major energy efficiency and indoor environment quality concern. Not all duct leakage is created equal, as some leakage occurs within the air-conditioned envelope and has marginal impact. Other times leakage goes directly to the outside or to non-air-conditioned spaces causing substantial heating and cooling energy losses. S/A leaks cause insufficient heating and cooling, which makes the occupants adjust the thermostat setting up or down to compensate for the lack of proper thermal comfort. R/A leaks may pull air from outside or from non-conditioned spaces directly into the duct system reducing both system efficiency and

capacity. The negative pressure will also draw with it humidity, dust, mold spores, insulation fibers and other contaminants. Air leakage in toilet and bathroom exhaust systems often requires larger fans that vent unnecessary conditioned air outdoors. Inability to properly ventilate these rooms may create odor and mold problems in the habitat.

### 1.1 Classifications

Duct leakage class (CL) is a valuable benchmark for comparing ductwork solutions before installation. The unit is cubic feet per minute (CFM) per 100 square feet of duct surface area. CL relates well to design factors as type of joints used in construction, the number of joints per unit length of duct, and the shape of the duct. Depending on the length of the duct system, leakage can account for a significant portion of fan capacity. Figure 3 depicts the most common duct interconnects and seams.

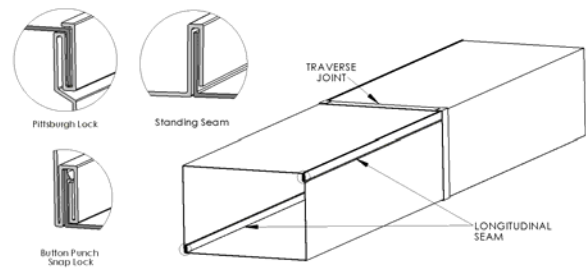

**Figure 3: Duct Interconnects and Seams - Pittsburgh Lock, Standing Seam and Button Pinch Snap Lock.**

Equation 1 forms the basis for CL, where the leakage rate (Q) is divided with the average static pressure p in inches of water gage in the power of 0.65.

$$CL = \frac{Q_{100^2ft}}{\left(\frac{p_{Upstream} + p_{Downstream}}{2}\right)^{0.65}} \quad (1)$$

For newly installed ducts, CL ranges from an average of 48 for unsealed rectangular ducts to three (3) for sealed round ducts. By using static pressure measurements, CL can be obtained in the field for a two by two square feet duct by capping off a 25 feet section of ductwork. In most cases the CL class will be higher in the field than calculated during design due to various factors related to workmanship, environment and service contractors. Workmanship often relates to the tightness of system fittings, access doors, dampers, and terminal boxes.

Poorly constructed dampers or improper sourcing of fittings promotes system leakage. It can be shown in a controlled experiment that when ductwork is not assembled correctly it may look perfect but excessive duct leakage results as the duct segments start to separate after only applying one inch w.g. static pressure. Over time, environmental factors such as tremors, water or settling of soil often take a toll on duct integrity as well. Two different examples are the separation of air ducts in wall penetrations due to tremors and the cracking of underground high-pressure airflow pipes due to settling of soil. In the duct separation case duct leakage was in excess of 50%. In the second example the cracked pipes partly filled with standing water which resulted in low airflow due to an increase in static pressure. Other issues are related to various service contractors' that often accidentally bump and drill into ductwork, or duct cleaners that cut frequent service openings. The provided examples illuminate some of the many CL shortcomings for field use. Nevertheless, the three main duct leakage classes are easy to remember: Class A – seal all penetrations, transverse joints and longitudinal seams, Class B: seal transverse joints and longitudinal seams and Class C – seal traverse joints only [14].

### 1.2 Costs of Duct Leakage

It is a daunting task to accurately quantify overall cost related to duct leakage in buildings [15-22]. Duct leakage impacts fuel consumption from various sources and the additional time the system modules must operate to satisfy thermostat demand. Duty cycle directly affects equipment lifetime costs and is a major savings contributor. The complexity increases further by the continuously changing outdoor conditions (temperature, humidity, wind and solar heating), varying internal loads (lighting, occupant numbers, computers and building pressure) and various exhausts (kitchen, ventilation, toilet and bathroom). Additional factors are both employee productivity and health costs that tie energy efficiency with IAQ. A simplified HVAC energy model is illustrated in Figure 4. The energy into the building is the heating fuel ( $Q_F$ ), and internal heat from occupancy load and electric devices ( $Q_I$ ). Heat flows out of the building are envelope leakage ( $Q_E$ ), boiler- ( $Q_{BE}$ ), bathroom and toilet- ( $Q_{BTE}$ ), kitchen- ( $Q_{KE}$ ), and HVAC ventilation- ( $Q_{VE}$ ) exhausts.

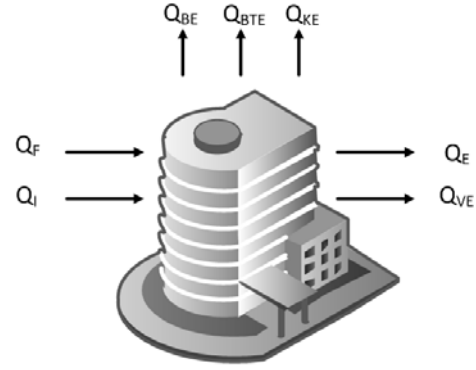

**Figure 4: An illustration of heat flows in a simplified building energy model.**

The overall climate adjusted fuel consumption is calculated by dividing the sum of heats less internal heat with the boiler efficiency ( $\eta_{BE}$ ) as shown in Equation 2.

$$Q_F = [Q_{VE} + Q_E + Q_{KE} + Q_{BTE} - Q_I] / \eta_{BE} \quad (2)$$

The calculated fuel consumption from a non-simplified version of this model is subtracted from the average annual fuel consumption for the building to find the building's **energy optimizing potential (EOP)**. As both the building envelope leakage and the internal heat load have been accounted for, the remaining difference is HVAC EOP. Duct leakage may be a substantial portion of this. The use of utility bills in this manner is very different from the common practice to inaccurately estimate energy savings from an actual energy conservation measure (ECM) that has been implemented.

The future of quantifying ECM savings need to rely on numerical calculations using actual measured data. Actual performance (Alt #1) should be compared to both the required and the projected ECM impacts. This may best be illustrated for a building where it is difficult to provide proper thermal comfort in all rooms. The typical solution today is to replace the installed heating and cooling capacity with new higher capacity units (Alt #2), when the issue may solely be duct leakage. Increased capacity typically requires higher airflow with associated static pressures that further elevate duct leakage. If leakage occurs within the air-conditioned envelope, continued challenges exist to properly balance the airflow to satisfy thermal comfort and if the air leakage is to the outside of the air conditioned envelope more conditioned air is lost. Increased capacity requires an upfront investment in tandem with a substantial increased operational energy cost. An alternative approach (Alt #3) is to seal the

ductwork and retain the installed heating/cooling capacity. Although the fan motor will consume more energy with properly sealed ducts, the savings will manifest itself in retaining the existing system and the reduced run time for the smaller chillers or boilers. A medical analogy may be the selection between ineffective treatments of a chronic disease compared to an effective cure.

A numerical example of duct leakage for a constant air volume system by **only** evaluating the fan motor while ignoring savings from chillers and boilers yields interesting findings. The duct leakage measured was 23% of a required 10,000 CFM airflow and 4% leakage remained after completed duct sealing. The energy delivered by the fan motor was determined by the motor efficiency ( $\eta$ ), power factor (pf), average current ( $I_{ave}$ ) and voltage ( $V_{ave}$ ) substituted into Equation 3. Note that the energy used is calculated using the electricity drawn from the circuit.

$$P = \sqrt{3} \cdot I_{ave} \cdot V_{ave} \cdot \eta \cdot pf \quad (3)$$

By using the consumed energy, an annual run time of 8760 hours, an electric rate of \$0.2 per kWh, airflow as measured, and adjustments for system curve parameters Table 1 results. The annual cost of energy consumption is found by multiplying annual run time with motor power and electric rate.

	Alt #1 Do Nothing	Alt #2 Treatment	Alt #3 Cure
	<i>Actual</i>	<i>Upgrade</i>	<i>Seal</i>
Power (KW)	1.41KW	3.05KW	2.46KW
Motor Power (HP)	2HP*	5HP	3HP
Air Delivered (CFM)	7,700	10,000	9,600
Energy Cost (yr. one)	\$2.47K	\$5.34K	\$4.31K
Investment (yr. one)	0	\$2K	\$8K
NPV Cost (10 yrs)	\$25.1K	\$56.2K	\$51.7K

**Table 1: Economic impact by the fan motor related to the three alternatives: Do Nothing (Alt #1), Upgrade System’s Capacity (Alt #2) or Seal Ducts (Alt #3). \*A 3HP motor that runs at 2BHP.**

The net present cost (NPC) of the projected 10 year investment and operational expenses were calculated using Equation 4 with a combined inflation and interest rate of 3% and projected annual electric rate increases of 4%.

$$NPC = \left[ \frac{R_1}{(1+i)^1} + \frac{R_2}{(1+i)^2} + \dots \right] + Investment \quad (4)$$

A very important observation is that Alt #1 - to do nothing about thermal comfort, IAQ and ignoring economic losses from chiller or boiler energy use – has a 10 year NPC of only \$25.1K compared to the two other alternatives. This economic advantage changes quickly when including impacts of increased load for the other system components. The leakage of air that has been filtered and conditioned generally results in an increased load on all HVAC system components, such as boilers, chillers, dehumidifiers, etc. These contributions require more advanced measurements and numeric calculations being outside the scope of this publication. For Alt #2 where a system capacity improvement is performed the initially installed fan motor of 3HP requires a 5HP replacement. The increased annual operation and the initial replacement cost push the 10 year NPC to \$56.2K. For Alt #3 the ducts were sealed to reach a delivered airflow of 9600 CFM. This airflow was increased to 10,000 CFM by adjusting the pulley. The system finally operates at design where all thermal and IAQ issues are mitigated at a lower 10 year NPC cost than Alt #2. Therefore, by **only** considering the saving impact by the fan motor the most economical alternative is to seal the ducts.

### 1.3 Duct Sealing Methods

Traditionally, few HVAC ducts have been sealed as energy was considered low-cost. Ducts sealed got sealants manually applied either internally during assembly or externally after installation. The application was completed using a brush and later by airless sprayers. Most new building construction now requires air ducts to be sealed as better awareness to workmanship and the installation process are emerging. However, in developed economies, at least half of the buildings that will be in use in 2050 have already been built [3]. This makes up a huge building inventory that needs to be tested and sealed. Three main methods of sealing ducts in existing buildings are currently available: manual, aerosolized adhesives and robotic application.

#### 1.3.1 Manual Brush and Spray Duct Sealing

Some contractors approach sealing ductwork externally in existing buildings as they do in new construction by using brush and airless sprayers. External application is a good

choice for ducts with negative pressure such as return and bathroom exhaust as the force vectors points inwards. Also for certain types of easily accessible suspended ductwork and where visual appearance is not important, manual application is a good approach. However, access to ductwork in existing buildings is a major issue due to hard ceilings, wall/floor penetrations, external duct insulation and for ducts next to walls or ceilings. Therefore the labor cost of properly exposing the ductwork is prohibitive unless made accessible through renovations and retrofits.

### 1.3.2 Aerosolized Adhesive Duct Sealing

Aerosolized adhesive duct sealing has been around for almost two decades but has not gained much traction even being one of only two options available to the industry for an extended time period [23]. The method is implemented by temporarily capping off all supply and returns grilles and injecting under pressure small aerosol particles suspended in the airflow. As the air makes a sharp turn to exit through a leak, the particles collide with and adhere to the leak edges to seal leakage points up to 5/8 inches across. There are no studies on the long-term integrity of the adhesive seals but the manufacturer warrantee is limited to **only** three (3) years for commercial buildings. Another question is how the “blind” application affects fire-dampers, duct sensors, reheat coils, variable air volume (VAV) boxes and the post-sealing static pressure drops. Some issues may be mitigated by taping and covering these devices ahead of injecting the glue. Another concern is how the deposited glue on the duct walls and other components affects the hygiene of the system. A quick laboratory test showed that dust quickly accumulates onto the glue and promotes an almost impossible to remove particulate as shown in Figure 5.



**Figure 5: Source removal is impossible after sealing.**

As particulate is a mold food source only humidity and mold spores are needed to enable growths. Humidity may enter the duct system as relative humidity, condensate,

water leakage or blow through water; all of which are common occurrences in these types of systems. The duct cleaning industry calls for complete source removal verified using a vacuum test or validated through an industrial hygienist’s particle counting process. A major concern is therefore the ability for ductwork sealed with aerosolized adhesives to pass the industry’s cleanliness protocols [13]. Furthermore, as source removal may consist of a combination of vacuum suction of 110” w.g., aggressive rotating high torque driven brushes or compressed air driven whips the process of source removal may reverse the duct leakage back to status quo. It has also been reported that tethers and hoses for duct cleaning equipment adhere to the residual adhesive in the duct thus preventing duct cleaning to take place at all and that the adhesive peel off in flakes after a few years.

### 1.3.3 Robotic Duct Sealing

Robotic duct sealing is a new application of a mature technology. A quick training program is required for new operators but the user threshold is low. A typical duct sealing robot system consists of an airless sprayer, a HVAC robot and a sprayer attachment as seen in Figure 6.



**Figure 6: An image of a HVAC robotic system setup. (Image provided by courtesy by Lloyds Systems LLC).**

The sealant is pumped by the airless sprayer from a 5-gallon pail to the sprayer applicator attached to the robot. Application of sealants by the system depends on if it is a Duct Leakage Class A, B or C. Class A sealing calls for a complete coverage, Class B calls for first sealing the longitudinal seams and then the traverse joints, and Class C is the easiest where sealant is only applied to traverse joints. Different styles of robots are needed for sealing vertical and horizontal ducts. Varying size ductwork



requires robots of different dimensions or adjustable spray attachments to get the nozzles close to the application area.

It is the operator's workmanship using video feedback that prevents sealant contamination on fire dampers, sensors, reheat coils and VAV boxes. Sealing around these devices and any access holes should to be done manually. Other known challenges for robotic application of duct sealants are related to proper positioning of the spray nozzles, ability to concurrently cross spray traverse joints, and to fill gaps bigger than ¼ inch. New synthetic polymers have a smooth non-tacky finish with low friction coefficients so the static pressure improves while better aerodynamics reduces particulate buildup in the ductwork. Furthermore, the new generation of duct sealants, do not crack in contrary to early market entry ones that are watered down high-viscosity substances.

### 1.4 Duct Sealing Verification Testing

All installed HVAC ducts leak, thus leak checks on all new and existing duct systems are highly recommended. Most leakage checks are not very accurate and/or not feasible on every part of the system due to the nature of the applied techniques [24-27]. Depending on the contractor's industry background certain methods are preferred to others independent of accuracy or applicability. Common methods used are static pressure, smoke, tracer gas, Pitot tubes, hot wire anemometer (HWA), and Time-Stepped Enthalpy (TSE) testing. All but static pressure and smoke testing also require flow hooding of the airflows delivered during normal air handler operation. The flow hood is held over each supply and return register and the flow rate for that register is recorded. These measurements are used to check the total air flow for the building and room-to-room air flow balance. Errors for active flow hood measurements are typically ±3% [25]. Characteristics of an ideal instrument to measure velocity fluctuations is good signal sensitivity, high frequency response, wide velocity range, minimal flow disturbance, good spatial resolution, low cost, high accuracy, ability to measure velocity components, ability to detect flow reversal and ease of use. However, in making measurements it is not just a question of the best instrument but rather which instrument will perform best for the specific measurement scenario.

The velocity pressure is small compared to the static pressure of air streams in most HVAC environments.

From Figure 7 it can be seen that the dynamic pressure may become a significant part of the total pressure when air velocities are increased, thus causing a substantial error contribution above 750 feet per minute (fpm).

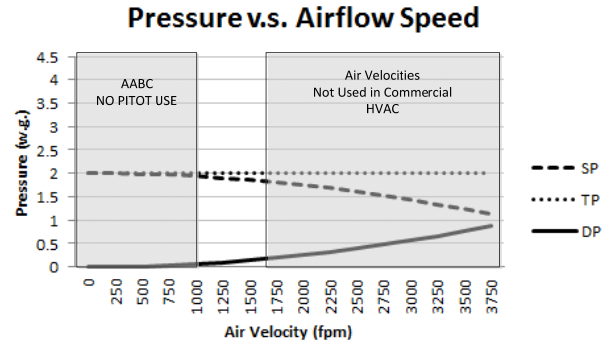

Figure 7: Static and velocity pressures related to total pressure and air velocity.

#### 1.4.1 Static Pressure (Orifice) Testing

An orifice meter is typically a conduit and a restriction to create a pressure drop that is measured to determine a volume flow rate. Homogeneous flows yield better measured accuracy, whereas variable velocity profiles in the cross section drastically reduces accuracy. Leakage tests pressurize the duct up to its pressure class rating and measure the airflow required to sustain this pressure [28-29]. Although the Orifice measurement itself is accurate the assumption that the static pressure is equal across the duct section length during operation is invalid. Figure 8 show how the static pressure drastically varies throughout the duct work thus an orifice based static pressure test will weigh leakage downstream substantially higher than upstream.

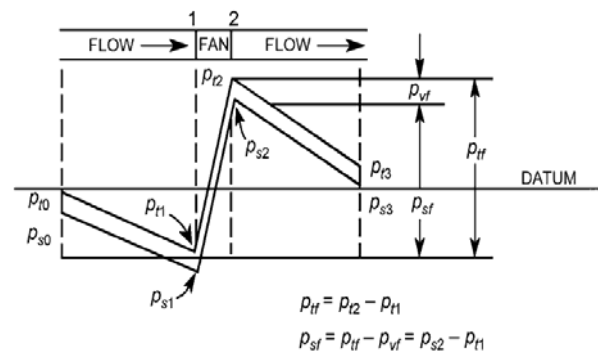

Figure 8: Static pressure profile of a HVAC duct with equal intake and outlet size.

### 1.4.2 Smoke Testing

The purpose of “smoke” testing duct systems is to locate and patch duct leakage. This procedure involves temporarily capping-off the register boxes and introducing theatrical fog into the duct system under slight pressure by heating the fogging fluid to vapor point. When using this qualitative testing method previously invisible leak points can be easily identified as the fog finds its way through any breaches in the duct system. The procedure is popular at rough-in at residential units. However, in existing homes and for commercial buildings the method is limited as the amount of duct leakage is not quantified and it is difficult to determine where the leakage originates.

### 1.4.3 Tracer Gas

The underlying concept of tracer gas testing is that a gaseous taggant is being dispersed in the air movement and then the concentration is measured to yield the volume flow rate by using formula 6 or 7 [31-34]. Tracer gas techniques can accurately measure the flow rate of air or other gases in a duct, stack, or pipe when conventional flow measurement techniques are inappropriate. It can therefore be used to calibrate several less accurate measurement methods. Furthermore, up till now it usually have been the only method that can be used to accurately measure the amount of outside air supplied to a building under actual operating conditions. Tracer gasses are typically non-reactive, non-toxic, odorless, colorless, and should be detectable by a recognized measurement techniques. The theory for tracer gas measurements comes from the mass balance equation (5).

$$\frac{dm}{dt}_{TG}^{Upstream} + \frac{dm}{dt}_{TG}^{Injection} = \frac{dm}{dt}_{TG}^{Downstream} \quad (5)$$

The equation shows that the mass rate of the tracer gas upstream added to the injected mass rate, equals the mass rate downstream where proper mixing has taken place. Substituting in a mass flow rate equal to the density times the volumetric flow rate before solving for the volumetric airflow ( $Q_{AIR}$ ) yields.

$$Q_{AIR} = \frac{\frac{dm}{dt}_{TG}^{Injection}}{\rho_{TR} \cdot (c^{Downstream} - c^{Upstream})} \quad (6)$$

By integrating Equation 6 as a function of time (t) the volumetric airflow rate may be determined without

knowing the instantaneous injection rate. Assume the upstream concentration changes linearly during injection and use the trapezoid formula to linearly integrate over n segments where  $i=1 \dots n$  while in tandem make both the pre- and post- background concentrations constant and average will yield Equation 7 where concentrations are measured in parts per million (ppm).

$$Q_{AIR} = \frac{m_{TR} \cdot 10^6}{\rho_{TR} \cdot T \left[ \frac{1}{2n} \sum_{i=1}^n (c_{i-1}^{Downstream} + c_i^{Downstream}) - \frac{1}{2} \cdot \left( \frac{1}{m} \sum_{j=1}^m c_j^{pre} + \frac{1}{L} \sum_{k=1}^L c_k^{Post} \right) \right]} \quad (7)$$

Several halon based tracer gases are being phased out due to the Kyoto protocol thus helium, hydrogen and CO<sub>2</sub> are increasing in popularity. However, CO<sub>2</sub> tracer gas has a downside as people produce CO<sub>2</sub> while plants absorb CO<sub>2</sub> to a level that may influence the measurements. Other known issues are lack of proper mixing of the tracer gas in the airstream, the high cost of the systems, and the substantial time required to perform measurements. The method also requires extensive knowledge and training before properly applying the method for accurate and repeatable results.

### 1.4.4 Pitot Tubes

The Pitot tube measures a fluid velocity by converting the kinetic energy of the flow into potential energy [35-38]. The conversion takes place at the stagnation point (z1), located at the Pitot tube entrance. The stagnation pressure (ps) is higher than the dynamic pressure and results from the kinetic to potential energy conversion. The stagnation pressure is measured by comparing it to the flow's static pressure (p2) using a differential manometer.

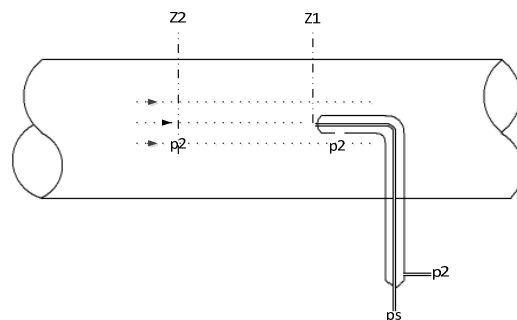

Figure 9: Cross-section of a Typical Pitot Static Tube

The Bernoulli equation states that the energy along a streamline is constant for incompressible flows, when less

than 30% of sonic velocity. Therefore the summation of the dynamic, static and hydrostatic pressures has to be constant as shown by Equation 8.

$$\frac{1}{2}\rho v^2 + p_{static} + \gamma h = C \quad (8)$$

Here the dynamic pressure is 0.5 times the density ( $\rho$ ) multiplied by the square of the flow velocity ( $v$ ). The hydrostatic pressure is the specific weight ( $\gamma$ ) times the elevation height ( $h$ ). By using Figure 9 and Equation 8 to evaluate two different points along a streamline, the Bernoulli equation yields,

$$\frac{1}{2}\rho v_{z1}^2 + p_{z1} + \gamma h_{z1} = \frac{1}{2}\rho v_{z2}^2 + p_{z2} + \gamma h_{z2} \quad (9)$$

The hydrostatic pressures cancel out for small distances as evaluated in HVAC systems. As  $z_1$  is a stagnation point the velocity is zero,  $v_{z1} = 0$ , thus Equation 9 reduces to:

$$\frac{1}{2}\rho v_{z2}^2 + p_{z2} = p_{z1} \quad (10)$$

Reorganizing Equation 10 to find the flow velocity ( $v$ ) at one point while using a more trivial naming convention yields Equation 11.

$$v = \sqrt{\frac{2 \cdot (p_{stagnation} - p_{static})}{\rho}} \quad (11)$$

The equation assumes measurements made in laminar, homogenous flow and since these conditions do not always exist in HVAC ductwork large errors can result if one is not careful. For this reason various strategies are used to average the flow components to determine a volumetric flow rate as illustrated in Equation 12.

$$\text{Volumetric Flow Rate} = A_{duct} \cdot \frac{1}{n} \sum_{i=1}^n v_i \quad (12)$$

The volumetric flowrate is expressed where  $A_{duct}$  is the cross sectional area,  $n$  is the number of points surveyed and  $v_i$  is the indicated velocity at each measurement point. Two preferred methods allow velocity measurements to simply be summed and averaged as shown in Equation 12. These are the Centroids of Equal areas or Log-Tchebycheff point distribution. It is the Log-Tchebycheff point distribution that is depicted in Figure 10.

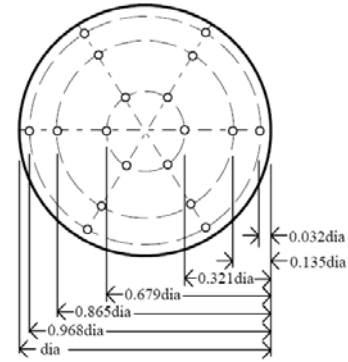

**Figure 10: Measuring points when traversing a round duct using the log-Tchebycheff method.**

As can be seen many different measurements are required to determine a volumetric airflow. The International Standard Organization (ISO) 3966 defines the currently accepted method for traversing ducts. The standard recommends a minimum of 25 points be measured in rectangular ducts. The uncertainty analysis presented in the standard clearly indicates that a number of systematic and random errors are associated with the technique, such as velocity fluctuations, turbulence (Reynolds number), pitot tube inclination, flow rate calculations and pitot tube positioning. Also a Log-Tchebycheff distribution makes assumptions that do not necessarily characterize the flow profiles of many HVAC duct systems, which have numerous fittings and disturbances. The ISO standard has also been adopted as the basis of ANSI/ASHRAE standard 111. It can also be mentioned that the Associated Air Balance Council (AABC) in their 2002 standard requires minimum average traverse velocities of not less than 1,000 fpm due to accuracy concerns. Many building codes, e.g. New York City Title 27/Subchapter 12 calls for a maximum airflow velocity of 750fpm in branch lines and 1000fpm in trunk lines; thus Pitot tube measurements are not recommended by AABC.

Pitot tube arrays are becoming more popular but these need to be calibrated using a secondary source. Furthermore, averaging mechanically yields a different arithmetic as they are only a single sensor device. The difference is illustrated in Equation 13.

$$\frac{\sqrt{p_{v1}}}{n} + \frac{\sqrt{p_{v2}}}{n} + \dots + \frac{\sqrt{p_{vn}}}{n} \neq \sqrt{\frac{p_{v1} + p_{v2} + \dots + p_{vn}}{n}} \quad (13)$$



### 1.4.5 Hot-Wire Anemometer

Hot wire, or thermal, anemometers use a very fine electrically heated wire so a fluid flowing past it has a cooling effect on it [39-44]. As the electrical resistance for platinum and tungsten are dependent upon the metal temperature a change in current occurs to maintain a constant wire temperature. Using convective heat transfer, the heat loss can be used to calculate the fluid speed. The voltage outputs from anemometers are the result of an electronic circuit within the device trying to maintain the specific variable (current, voltage or temperature) constant. Figure 11 illustrates a constant temperature hot wire anemometer with a Wheatstone bridge.

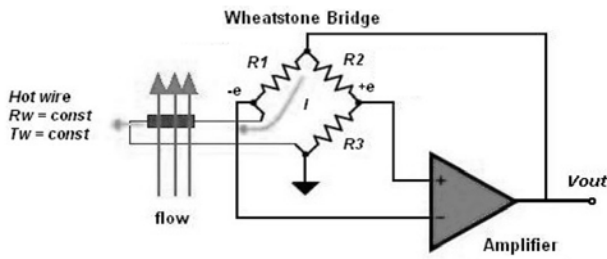

**Figure 11: Constant temperature HWA with a bridge.**

The physical relation that describes the temperature of a single wire is realized in Equation 14. A conduction loss is followed by the heating energy less the thermal energy storage and the natural convection heat loss. The heat transfer due to radiation and natural convection are both neglected. Radiation for most HWA is very small while natural convection is only effective at low flow velocities when the cubed root of the Grashof (Gr) number is smaller than Reynolds Number (Re).

$$-k_w A_w \frac{\partial^2 T_w}{\partial x^2} + \frac{I^2 \chi_w}{A_w} - \pi d_w h (T_w - T_a) - \rho_w c_w A_w \frac{\partial T_w}{\partial t} = 0 \quad (14)$$

The related parameters in equation 14 are described as:

$\rho_w$ = wire material density	$I$ = Heating Current
$c_w$ = Specific heat of wire	$\chi_w$ = wire resistivity
$A_w$ = wire cross-section	$d_w$ = wire diameter
$T_w$ = Wire temperature	$h$ = heat transfer coefficient
$k_w$ = Conduction constant	$x$ = wire length
$t$ = time	$T_a$ = fluid temperature

An equilibrium condition that requires the heat storage to be zero and the wire length over diameter aspect ratio is large will eliminate the conduction contribution. The resistance of the sensor element can be approximated as a

linear function of temperature as shown in Equation 15 where  $R_a$  is the wire resistance at the fluid temperature.

$$R_w = R_a [1 + \alpha_a (T_w - T_a)] \quad (15)$$

By keeping the temperature of the heated wire to the ambient constant by the Wheatstone bridge the electric current will be proportional to the mass flow. The King's law as shown in Equation 16 is an empirical solution to Equation 14 where the voltage drop (V) is used as a measure for the fluid velocity (v). The constants A, B and the exponent n are empirically determined and are ambient specific.

$$V^2 = (T_w - T_a)(A + Bv^n) \quad (16)$$

Additional assumptions are uniform temperature across wire length, uniform low velocity air flows normally across the wire, constant fluid temperature and density, and a Reynolds number less than 140. For all actual measurements direct calibration of the anemometer is necessary. The exponent n may be assumed to be in the range of 0.45 to 0.5 for HWA. A and B are found by measuring the voltage, V, obtained for a number of known flow velocities and performing a least squares fit for the values of A and B. ASTM Standard D 3464-75, "Standard Test Method for Average Velocity in a Duct Using a Thermal Anemometer" specifies 4 to 20 sampling points, depending on the size of the duct.

### 1.4.6 Time-Stepped Enthalpy

TSE is a new method [45-49] to accurately measure airflow in HVAC systems. TSE is based on psychrometrics and thermodynamics and utilizes various measurements to quantify the energy released into or extracted from an HVAC system as seen in Equation 17. The energy value ( $Q_F$ ) is substituted into the total heat formula shown as Equation 18 to calculate the airflow volume. For a hydronic cooling system only three measurements are required to quantify the energy extracted from the building's HVAC airflow: fluid volume flow ( $V_{fluid}$ ) and the temperatures in and out of the heat transfer device. These measurements are substituted into the hydronic system Equation 17 to quantify the total heat.

$$Q_F \left( \frac{BTU}{hr} \right) = V_{fluid} \left( \frac{G}{min} \right) \cdot 60 \left( \frac{min}{hr} \right) \cdot 8.33 \left( \frac{lb}{G} \right) \cdot 1 \left( \frac{BTU}{lb \cdot ^\circ F} \right) \cdot \Delta T (^{\circ} F) \quad (17)$$

The constants provided in the equations are derived for systems running at sea level and therefore will be adjusted for those running at higher elevations. Nevertheless, the total heat  $Q_F$  is found by converting the fluid flow in gallons per minute into gallons per hour which is multiplied with the weight of one standard gallon of water times the heat content variable times the delta temperature of the fluid flow. The total heat  $Q_A$  transferred into or extracted from the airflow is equal to the  $Q_F$  transferred by the fluid flow to satisfy the first two laws of thermodynamics. Should the fluid be changed to a glycol mixture the specific gravity of the fluid will be determined and the flow's heat content capacity corrected to the specific gravity value. To find the actual airflow  $Q_F$  is substituted as the total heat  $Q_A$  into Equation 18 along with delta enthalpy. Enthalpy measurements are obtained by means of an enthalpy meter:  $h_1$  is measured when the system is running at full capacity,  $h_2$  is measured when no heat transfer is taking place. All constant heat contributions will automatically cancel out as one of the two measured parameters is a baseline.

$$Q_A \left( \frac{BTU}{hr} \right) = V_{airflow} \left( \frac{cf}{min} \right) \cdot 4.5 \left( \frac{min \cdot lb}{hr \cdot cf} \right) \cdot \Delta h \left( \frac{BTU}{lb} \right) \quad (18)$$

#### 1.4.7 Measurement Techniques Compared

Table 2 is a summary of the described methods. Some of the methods listed require laminar flow to yield high accuracy but laminar flows are often not present in HVAC systems. Furthermore, measuring the duct leakage by using orifices, being intrinsically a very accurate method, is often inaccurate when applied to duct leakage (as explained in section 1.4.1). From the table it can be seen that both tracer gas and TSE provides sufficient accuracy for duct leakage assessments. Both work well in turbulent HVAC airflows.

Method	Accuracy	Time	Flow	Calibration
Static Pres.	Low	60	no	no
Smoke	N/A	60	any	N/A
Pitot Tubes	±3%	120	laminar	yes
HWA	±3%	30	laminar	yes
Tracer Gas	±1%	120	turbulent	no
TSE	±1%	15	turbulent	no

**Table 2: Comparison between existing measurement techniques**

## 2 HVAC ROBOTIC DUCT SEALING SETUP

Robotic inspection has been used for many decades to visualize difficult to reach places. As inspection robots became better other payloads were added to execute various functions and tasks. Duct cleaning was implemented early on using either rotating brushes or compressed air whips. Newer HVAC robots allow more advanced airless sprayer attachments to apply sealants in ductwork. Existing systems may operate horizontally in ducts from five inches up to five feet in diameter and vertically from eight inches up to nine feet in diameter. In the presented efforts both horizontal and vertical HVAC robots were used.

### 2.1 HVAC Robotics

For supply and return duct case studies a horizontal HVAC robot was utilized. The system was configured to seal ducts from 8 inches up to 30 inches in diameter as shown in Figure 6. The process often requires the fan motor to be shut off while a HEPA filtered negative air machine create a negative airflow to extract dust and debris from the ductwork ahead of applying the sealants. A simple rule is to clean forward in the airflow direction and then spray sealant in reverse to prevent camera overspray.

### 2.2 Self-Centering Spray-Head

High quality duct sealants are made of expensive synthetic polymers and therefore it is desired to minimize the amount of applied material. This was the motivation behind developing systems that automatically self-center in the duct work as illustrated in Figure 12.

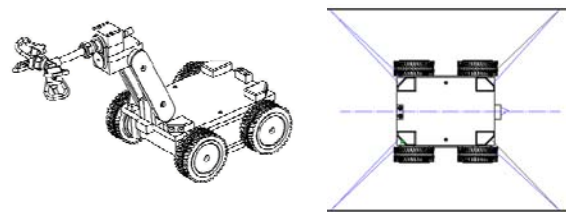

**Figure 12: Self-Centering Sealant Applicator**

Self-centering is enabled by feeding sensor data to a PID controller that keeps the robot on the horizontal centerline. Another sensor measures the height of the duct and uses this input to position the rotating head in the center of the duct. For round ducts the spraying

application takes place with constant rotation. For rectangular or oval ducts a speed profile for even application is needed. This allows for quick and effective robotic sealing of ducts. A similar approach is used for vertical duct robots although the propulsion system is different.

### 2.3 Manual Spraying of Service Openings

Robotic sealing of ducts sometimes requires manual application in certain places. It is especially important where service openings are made into the system by fire-dampers, VAV and reheat coils. Figure 13 shows two operators hand sealing around service opening.



**Figure 13: Manual sealing around a service opening.**

Figure 14 depicts finished Class A sealing method using robotic application.



**Figure 14: Class A robotic application of sealant.**

## 3.0 DATA COLLECTION/ANALYSIS

Although substantial before and after duct sealing verification data has been collected at various sites throughout this effort, this publication focuses on three cases having high information content and average results. In the selected cases reasonable laminar flow existed to allow accurate Pitot tube and HWA flow measurements. Flow hood measurements were applied in tandem to quantify the amount of leakage before and after duct sealing.

Another objective was to prove the versatility of HVAC robotic duct sealing and to illuminate some of the similarities and differences between duct sealing of return-air, supply-air and bathroom exhaust ducts. The sealing of the return and supply ducts was performed at the same location. Medical staff had complained about inadequate system performance and therefore initiated a retrofit project that installed a new direct expansion (DX) system with a desiccant wheel dehumidifier to deliver the needed cooling to the OR. The Hydronic system was kept as a redundant backup thus existing ductwork was intact and separated from the new by supply and return isolation dampers. The bathroom and toilet exhaust system was at a separate location and the issues were insufficient ventilation to meet building codes and to eliminate possible microbial growth.

### 3.1 Return Duct System

The return ductwork was a good candidate for Pitot tube measurements as almost perfect conditions for laminar flow existed at both measurement points. Repeated measurements yielded consistent air volume measurements of 4796 CFM at air-handler and 3701 CFM at the intake before sealing. After robotic sealing the before, after and difference airflows are listed in Table 3.

	Air Handler	Intake	Difference
<b>Before</b>	4796	3701	1095
<b>After</b>	4796	4450	346
<b>Difference</b>	0	749	749

**Table 3: Return duct before and after sealing airflows.**

The totals indicate a reduction in the unaccounted return air of 749 CFM or 16%. It is assumed that the remaining leakage of 346 CFM is from the return isolation damper that was not sealed. Therefore, to further reduce the leakage it is recommended that a bubble damper be installed in place of the existing leaking one. The R/A

leak pulled in air from the boiler room. This air held a substantial higher temperature, thus reducing both the system efficiency and capacity. The negative pressure also drew with it dust, mold spores, insulation fibers and other contaminants.

### 3.2 Supply Duct System

The supply ductwork was also a good candidate for Pitot tube measurements as good conditions for laminar flow existed in the trunk line while the registers were flow hooded using an active device. Repeatable and consistent air volume measurements of 5560 CFM at air-handler and 4515 CFM at registers were made. The measured airflows before and after duct sealing are listed alongside their difference in Table 4.

	<b>Air Handler</b>	<b>Registers</b>	<b>Difference</b>
<b>Before</b>	5560	4515	1045
<b>After</b>	5560	5065	495
<b>Difference</b>	0	550	550

**Table 4: S/A before and after sealing.**

The reduction in S/A duct leakage was 550 CFM or 10%. The remaining leakage of 495 CFM is attributed to the unsealed return isolation damper. Therefore, to further reduce the leakage it is recommended that a bubble damper is installed in place of the existing leaking one.

The overall impact of sealing 1244 CFM of air leakage in the return and supply air provided enough additional capacity to maintain the required 60-62 F temperature in the surgery suites. It also eliminated the intrusion of hot air into the return air trunk as it passed through the boiler room, thus dramatically improving the unit’s efficiency and cooling capacity. The temperature difference before sealing was 6.4F and only 0.8F afterwards. The combined S/A and R/A leaks caused insufficient heating and cooling that made occupants adjust the thermostat setting to compensate the lack of proper thermal comfort.

### 3.3 Exhaust Duct System

To properly manage proper ventilation of odors and humidity in bathrooms and toilets many building codes call for minimum ventilation. When the natural ventilation is not sufficient the requirements vary but typical residential values are 20 CFM continuous or 50 CFM intermittent operation. The continuous residential value was the underlying building code for this study. An active flow-hood was used to measure register ventilation

and a custom capture hood captured the exhausted air volume. Based on the building code the 40 ventilation units were supposed to draw 800 CFM. However, the system was unbalanced and the total ventilation from the bathrooms and toilets was only 621 CFM. The total exhausted air-volume was 1582 CFM. The system was therefore continuously pulling 961 CFM of additional conditioned air from the building.

A vertical spray robot was used to seal the exhaust trunk by first using backdrop fillers before a synthetic polymer sealant was used to create the final seal. The airflow dynamics changed significantly where the static pressure substantially increased indicating less airflow while the ventilation rates substantially improved in most bathrooms and toilets. To accommodate a reduced airflow the fan motor was replaced with a smaller one and the ventilation units were then balanced to approximately 20 CFM. The new ventilation exhaust draw was 974 CFM a reduction of 608 CFM or 39%. The IAQ benefits can be added to the energy reduction benefits acquired by duct sealing. Proper ventilation of odors and humidity from showers, baths and toilets will prevent the spread of odors and mold growth in the residences.

## 4. CONCLUSION

The presented research show that robotic application of reliable long-term synthetic polymer sealants mitigated thermal comfort, exhaust fan noise pollution, cooling capacity, OR hygiene, odor ventilation and humidity ventilation. Quantitative analysis using different measurement techniques quantified the duct leakage reductions of approximately 16%, 10% and 39% of overall airflow that mitigated all reported issues as well as associated energy usage and load on the systems. It was found that duct sealing not only improves facility energy efficiency but it also has a substantial impact on the indoor environment. Although the verification and validation methods presented in the effort rely on Pitot tubes, HWA and flow hoods - knowledge of how to make accurate measurements using these instruments is very important. Tracer gas and TSE measurements are both options to calibrate other non-accurate methods. Manual or robotic application of properly designed sealants is the only recommended duct sealing approach for hospitals or health care facilities. It is very important to facilitate proper duct hygiene and integrity of the seal envelope long-term.

## 5. ACKNOWLEDGEMENTS

Thanks to the team at Lloyds Systems LLC for financially supporting this effort, Carlisle HVAC for providing duct sealants, Bob Carlson PE for third party measurements data and to South Dakota School of Mines faculty for assisting and directing this research. Without their effort, the completion of the project would not have been possible.

## 6. REFERENCES

- [1] U.S. Energy Information Administration, "Annual Energy Review", September 27, 2012
- [2] U.S. Energy Information Administration, "World energy demand and economic outlook", September 19, 2011
- [3] C. Marnay, M. Stadler, et al. "A Buildings Module for the Stochastic Energy Deployment System", Lawrence Berkeley National Laboratory, 2008, Report LBNL-291
- [4] S. Wilson and D. Straus, "The Presence of Fungi Associated with Sick Building Syndrome in North American Zoological Institutions", *J Zoo Wildl Med.* 2002 Dec; 33(4): 322- 7
- [5] T. Tominaga, M. Sekine and H. Oyaizu, "Tracing the Contamination Origin of Coliform Bacteria in Two Small Food-Processing Factories", Saitama Industrial Technology Center North Institute. *J Food Prot.* 2008 Sep;71(9):1910- 4
- [6] S. Wilson, R. Palmatier, et. al, "Mold Contamination and Air Handling Units", *J Occup Environ Hyg.* 2007 Jul;4(7):483- 91
- [7] F. Perdelli, M. Cristina, et. al. , "Fungal Contamination in Hospital Environments", *Infect Control Hosp Epidemiol.* 2006 Jan;27(1):44- 7. Epub 2006 Jan 6
- [8] U. Kelkar, A. Bal, and S. Kulkarni, "Fungal Contamination of Air Conditioning Units in Operating Theatres in India", *J Hosp Infect.* 2005 May;60(1):81- 4
- [9] G. Graudenz, C. Oliveira, et. al., "Association of Air-Conditioning with Respiratory Symptoms in Office Workers in Tropical Climate", *Indoor Air.* 2005, Feb 15(1): 62- 6
- [10] ANSI/ASHRAE Standard 62.1-2010, "Ventilation for Acceptable Indoor Air Quality", ISSN 1041-2336
- [11] ANSI/ASHRAE Standard 55-2010, "Thermal Environmental Conditions for Human Occupancy", ISSN 1041-2316
- [12] W. Guo, "Technologies Toward Thermal Comfort-Based and Energy-Efficient HVAC Systems: A Review", *Systems, Man and Cybernetics, SMC, IEEE, San Antonio, 11-14 Oct. 2009*
- [13] NADCA, "Assessment, Cleaning, and Restoration of HVAC Systems", ACR 2006
- [14] SMACNA, "HVAC Systems Duct Design Manual", 1990
- [15] T. Maile, "Comparing Measured and Simulated Building Energy Performance Data", Thesis (Ph.D.). Stanford University, 2010
- [16] Y. Li, J. Wu, et. al. "Modeling and Energy Simulation of the Variable Refrigerant Flow Air Conditioning System with Water-Cooled Condenser under Cooling Conditions", *Energy and Buildings,* (41:9), pp. 949-57, 2011
- [17] M. Barba, "HVAC Optimization for Energy Savings - The Payback on Waste Elimination Can be Measured in Months, not Years, and Savings Can be Very Significant", *Buildings – Smarter Facility Management,* 12/01, 2009
- [18] A. Smith, N. Fumo, et. al., "Robustness of a Methodology for Estimating Hourly Energy Consumption of Buildings Using Monthly Utility Bills", *Energy and Buildings,* (43:4), pp. 779-786, 2011
- [19] B. Thornton, M. Rosenberg, et. al. "Achieving the 30% Goal: Energy and Cost Savings Analysis of ASHRAE Standard 90.1-2010", PNNL-20405, BT0703000, Pacific Northwest National Laboratory (PNNL), pp 368, 2010
- [20] A. Hinge, and D. Winston, "Documenting Performance - Does it Need to be so Hard?", *High Performing Buildings, ASHRAE,* pp. 18-23, 2009
- [21] M. Leach, "Technical Support Document Strategies for 50% Energy Savings in Large Office Buildings", NREL/TP-550-49213. Golden, CO: National Renewable Energy Laboratory. xviii, pp 141, 2010
- [22] V. Erickson, M. Carreira-Perpinan, and A. Cerpa, "Observe: Occupancy-Based System for Efficient Reduction of HVAC Energy", *Information Processing in Sensor Networks (IPSN), 2011 10th International Conference,* pp. 258-269, April 12-14, 2011
- [23] Aeroseal, <http://www.aeroseal.com/problem-we-solve/faq-commercial.html>



- [24] Z. Bradshaw, "An Introduction to Turbulence and Its Measurement", Pergamon Press, Oxford. DOI: 10.1017/S0022112072281721
- [25] I.S. Walker, C.P. Wray, C. Guillot and S. Masson, "Evaluation of Commercially Available Techniques and Development of Simplified Methods for Measuring Grille Airflows in HVAC Systems", Environmental Energy Technologies Division, LBNL 51551, August 2003.
- [26] G. Williams, "Air System Basics", Heating/Piping/Air-Conditioning, May 1995
- [27] J. M. Saleh, "Fluid Flow Handbook", 2002, McGraw-Hill Professional
- [28] M. Zedan, and R. Teysandier, "Effect of Errors in Pressure Tap Locations on the Discharge Coefficient of a Flange-Tapped Orifice Plate", Flow Measurement and Instrumentation, Volume 1 Number 3, April 1990.
- [29] ISO 5167-1, "Measurement of Fluid Flow by Means of Pressure Difference Devices -- Part 1: Orifice Plates, Nozzles and Venturi Tubes Inserted in Circular Cross-Section Conduits Running Full", International Standard, ISO 5167-1, 1991
- [30] K. W. Cheong, "Tracer Gas Technology for Airflow Measurements in HVAC Systems", International Journal of Energy Research, Volume 20, Issue 12, pages 1081–1093, December 1996
- [31] A. Kiwan, W. Breg., et. al., "Tracer Gas Technique, Air Velocity Measurement and Natural Ventilation Method for Estimating Ventilation Rates Through Naturally Ventilated Barns", Agric Eng. Int: CIGR Journal, 2012, Vol. 14, No 4., pp. 22-36
- [32] ASTM E741, "Standard Test Method for Determining Air Change in a Single Zone by Means of a Tracer Gas Dilution", Conshohocken, Pennsylvania: American Society for Testing and Materials, 2000
- [33] ANSI/ASHRAE Standard 129-1997, "Measuring Air-Change Effectiveness", Atlanta, GA: American Society of Heating, Refrigerating and Air-Conditioning Engineers, Inc., 2002
- [34] M. Sherman, "Tracer-Gas Techniques for Measuring Ventilation in a Single Zone", Building and Environment, 1990, Vol. 25, No. 4, pp. 365-374
- [35] B. Dobrowolski, M. Kabaciński, J. Pospolita, "A Mathematical Model of the Self-Averaging Pitot Tube: A Mathematical Model of a Flow Sensor", Flow Measurement and Instrumentation, 2005, vol. 16, pp. 251-265
- [36] D. Weceł, T. Chmielniak, J. Kotowicz, "Experimental and Numerical Investigations of the Averaging Pitot tube and Analysis of Installation Effects on the Flow Coefficient", Flow Measurement and Instrumentation, 2008, vol. 19, pp. 301-306
- [37] M. Kabacinski, P. Pospolita, "Numerical and Experimental Research on New Cross-Sections of Averaging Pitot Tubes", Flow Measurement and Instrumentation, 2008, 19:17-27
- [38] Z. Limin, "Experimental Research of Averaging Pitot Tube Flow Sensors with Flow Conditioning Wing", Electric Information and Control Engineering (ICEICE), 15-17 April 2011, pp. 382 - 385
- [39] X. Lomass, "Fundamentals of Hot-Wire Anemometry", Cambridge Univ. Press., DOI: 10.1002/zamm.19880680215, 1986
- [40] H. Bruun, "Hot-Wire Anemometry: Principles and Signal Analysis", Oxford University Press Inc., New York, 1995
- [41] N. Khamshah1, A. Abdalla, S. Koh, and H. Rashag, "Issues and Temperature Compensation Techniques for Hot Wire Thermal Flow Sensor: A Review", International Journal of the Physical Sciences Vol. 6(14), pp. 3270 – 3278, 18 July, 2011
- [42] F. Ferreira, "Hot-Wire Anemometer With Temperature Compensation Using Only One Sensor", IEEE Trans. Instrumentation Measurement, 2001, 50(4): 954-958
- [43] S. Hancock, "Pulsed-Wire Anemometry Near Walls", Exp. Fluids, 1998, 25: 151–159
- [44] C. Sosna, R. Buchner, "A Temperature Compensation Circuit for Thermal Flow Sensors Operated in Constant-Temperature-Difference Mode. Instrumentation and Measurement", IEEE Trans., 2010, 59(6): 1715-1721
- [45] B. Askildsen, C. Tolle, et.al, "Time-Stepped Enthalpy Software Application", Submitted to 27th International Conference on Computers and Their Applications (CATA-2013), Honolulu, Hawaii, March 4-6, 2013
- [46] B. Askildsen, C. Tolle, et.al, "Time-Stepped Enthalpy Software Application", 27th International

Conference on Computers and Their Applications  
(CATA-2013), Honolulu, Hawaii, March 4-6, 2013

[47] B. Askildsen, C. Tolle, et.al, "Time-stepped enthalpy method to quantify HVAC airflow volume", AIRAH Achieving the Green Dream Conference, Sydney, 2012

[48] B. Askildsen and L. Weaver, et. al., "U.S. Patent Application 61/355,947", 2011

[49] L. Rock and B. Askildsen et. al., "U.S. Patent Application 20100286957", May 5, 2010